

**matev**

# **MOW-FM 190**

Operating Manual

**Front mower**



matev GmbH  
Nürnbergerstr. 50  
D-90579 Langenzenn  
Phone.: +49 (0) 9101 90870

Errors and changes excepted!

Status: 17.11.2020  
Reference number: BA-MOW-37858

# Order numbers

<b>Artikelnummer</b>	<b>Bezeichnung</b>
131 8921	MOW-FM 190 basic unit front mower
131 8403	MOW-H/M-190 CM Mähwerk Grunddeck mit Fahrrahmen starr
131 7861	MOW-H 190 FM Frontmähwerk Grunddeck

---

# Table of contents

Table of contents .....	2
<b>1</b> Introduction .....	4
<b>2</b> About this operating manual .....	5
<b>3</b> Technical data .....	6
3.1 Power diagram, hydraulic .....	7
<b>4</b> General safety notices .....	8
4.1 Presentation of the general safety notices .....	8
4.2 Intended use .....	8
4.3 Instructions for the owner .....	9
4.3.1 Qualifications of personnel .....	9
4.3.2 Accident prevention .....	9
4.3.3 Instruction .....	9
4.4 Warning signs .....	9
4.4.1 General warning signs .....	9
4.4.2 Machine-specific notice .....	10
4.5 Safety devices .....	11
4.5.1 Protective device on the machine .....	12
4.5.2 Safety notices on the machine .....	17
<b>5</b> Equipmentvariants .....	20
5.1 Basic implements with rigid or hydraulic driving frame .....	20
5.2 Optionally required accessories .....	20
5.2.1 Attachments .....	20
5.2.2 Mower inserts .....	20
5.2.3 Drive kits .....	21
5.3 Required accessories .....	22
5.4 Optional accessories .....	22
<b>6</b> Operation of the mower .....	24
6.1 Application area .....	24
6.2 Function .....	24
6.3 Instructions for mowing .....	24
6.3.1 Clean the work terrain before mowing .....	24
6.3.2 Mowing irregular areas .....	25
6.3.3 Mowing large areas .....	25
6.3.4 Mowing small areas .....	25
<b>7</b> Installation .....	26
7.5 Operation of the mower .....	29
7.6 Secure the mower for road travel to the work site .....	30
7.7 Adjusting the mower incline .....	31

---

7.7.1	Adjusting the inclination angle on the driving frame.....	32
7.8	Adjusting the cutting height for the rigid driving frame .....	33
7.9	Adjusting the cutting height on the hydraulic frame.....	34
7.10	Moving the mower into maintenance position .....	35
7.11	Adjusting the air supply .....	37
7.12	Securing the lawn harrow for road travel to the work site.....	38
7.13	Move the lawn harrow into transport position.....	38
7.13.1	Adjusting the angle of inclination of the tines.....	40
7.13.2	Changing the plunge depth of the tines.....	41
<b>8</b>	<b>Maintenance.....</b>	<b>42</b>
8.1	Safety when performing maintenance .....	42
8.2	Maintenance.....	42
8.2.1	Daily maintenance tasks .....	42
8.2.2	Weekly maintenance tasks or after 25 operating hours .....	43
8.2.3	Mower blades .....	43
8.2.4	Mounting the V-belt.....	43
8.3	Cleaning and care .....	44
8.4	Lubricating schedule .....	45
8.4.1	Maintenance schedule for the mower.....	46
8.4.2	Maintenance schedule for the mower.....	47
<b>9</b>	<b>Fault .....</b>	<b>48</b>
<b>10</b>	<b>Repair .....</b>	<b>49</b>
<b>11</b>	<b>Disposal .....</b>	<b>50</b>
<b>12</b>	<b>Warranty.....</b>	<b>50</b>
<b>13</b>	<b>List of illustrations.....</b>	<b>51</b>
<b>14</b>	<b>List of tables .....</b>	<b>51</b>
<b>15</b>	<b>EG – Declaration of Conformity .....</b>	<b>52</b>

# 1 Introduction

We welcome you to the matev family

and thank you for purchasing a matev GmbH product, we appreciate your trust. You have acquired a quality product, if contrary to expectations you should have problems with the implement, contact your responsible sales partner.

Company stamp – sales partner

Before using the product for the first time, please read this operating manual carefully and conscientiously all the way through. The manual describes the handling of the implement in detail and will support you in working safely and effectively.

For damage that occurs due to improper use, we will not accept any warranty claims.

Variants may be described in the manual that do not match the scope of delivery of your implement.

Please enter the data of the rating plate on the implement in the manual. This information will be helpful in communication if there is a service case.



The image shows a black rectangular rating plate with white text and a CE mark. The text on the plate includes the company name 'matev GmbH', the address '90579 Langenzenn', and five input fields for technical specifications: 'Modell:', 'Code Nr.:', 'Fabr. Nr.:', 'Baujahr:', and 'Ges.Gew.:'. The CE mark is located to the right of the address.

The matev products are subject to change in the interest of technical progress. All information, illustrations, and technical specifications represent the latest status at the time this manual was published. The manufacturer reserves the right to make changes at any time in the interest of technical progress.

Regards

matev GmbH

## 2 About this operating manual

Prior to first use, read the manual carefully and conscientiously all the way through.

Keep this manual where it is easily accessible. This will enable you to refer to important information and handling instructions as needed.

At transfer of the machine the owner of the machine receives instruction in the operation and maintenance of the machine from the owner's sales partner.

The owner must ensure that operating and maintenance personnel have been instructed in full scope in the operation and maintenance of the machine.

Listings with bullet points are marked as follows:

- Text
- Text
- Text . . .

Handling instructions are marked in the sequence, in which they should be executed, as follows:

1. Text
2. Text
3. Text . . .

If directions (left, right, rear, front) are specified in the operating manual, these directions are always based on the direction of travel of the carrier vehicle.

The direction of travel of the front PTO shaft is always specified from the front as viewed from above. Right rotation CW (clockwise), left rotation CCW (counterclockwise).

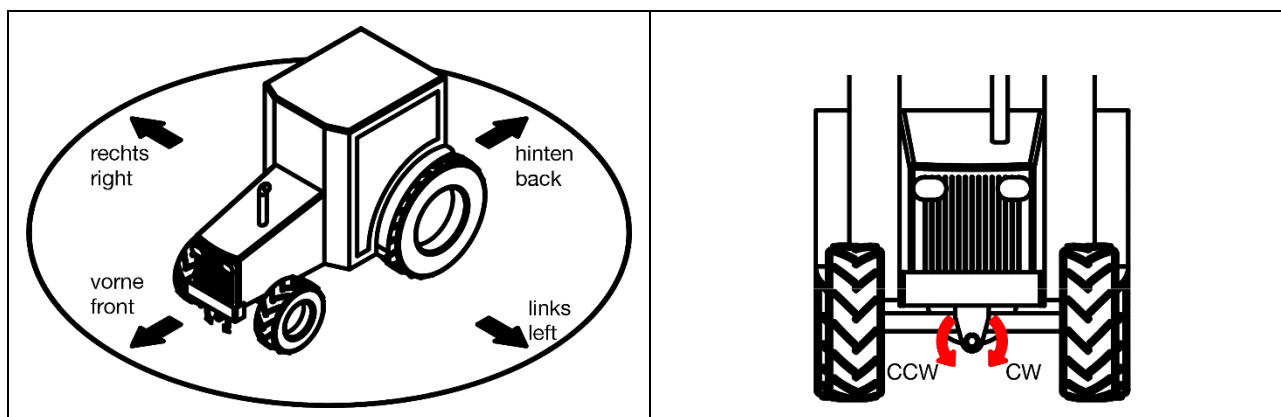

Fig. 1: Definition of alignment and direction of rotation

<b>3 Technical data</b>			
<b>Technical data</b>	<b>MOW - 140 CM</b>	<b>MOW - 160 CM</b>	<b>MOW - 190 CM</b>
Dimensions (L/W/H) in mm	1,343x1,425x535	1,452x1,625x535	1,564x2,146x535
Cutting width	1370 mm	1570 mm	1870 mm
Cutting height from - to With hydraulic frame	X	28 mm - 97 mm	X
Cutting height from - to With rigid frame	15 mm 135 mm	28 mm - 119 mm	15 mm 135 mm
Required minimum capacity of the carrier vehicle	From 23 hp / 17 kW	From 23 hp / 17 kW	From 34 hp / 25 kW
<b>Gear oil / lubricating grease</b>			
Gearbox fill quantity	0.4 l	0.8 l	0.8 l
Gear oil	Viscosity class 90, e.g. Shell Spira MB90		
Gear oil change	<b>After the first 50 h, then every 500 h</b>		
Lubricating grease	All purpose grease with a temperature resistance from -30 °C to +130 °C, for example, mineral-based, lithium universal lubricating grease or similar products.		
<b>Possible drive configuration</b>			
Front PTO shaft	1,000 rpm CW/CCW		
	2,000 rpm CW/CCW		
Hydraulic	X	38 - 42 l/min	43 - 47 l/min
	X	43 - 47 l/min	48 - 52 l/min
<b>Weight / tire pressure</b>			
Weight, at least	202 kg	246 kg	277 kg
Tire pressure	1.5 bar		

Table 1: Technical data

### 3.1 Power diagram, hydraulic

Please use the diagram below to assess whether your vehicle has enough hydraulic power available.

1. Add the power specifications of all options present on your machine.
2. Be aware of the information concerning the hydraulics of your vehicle.



**As a rule, the hydraulic power of your vehicle that is available for additional implements, is considerably lower than the engine power.**

3. Enter the information in the table below: Example: maximum hydraulic pressure on the vehicle 150 bar. Oil volumetric flow of 40 l/min. equals a maximum hydraulic power of 8.8 kW.

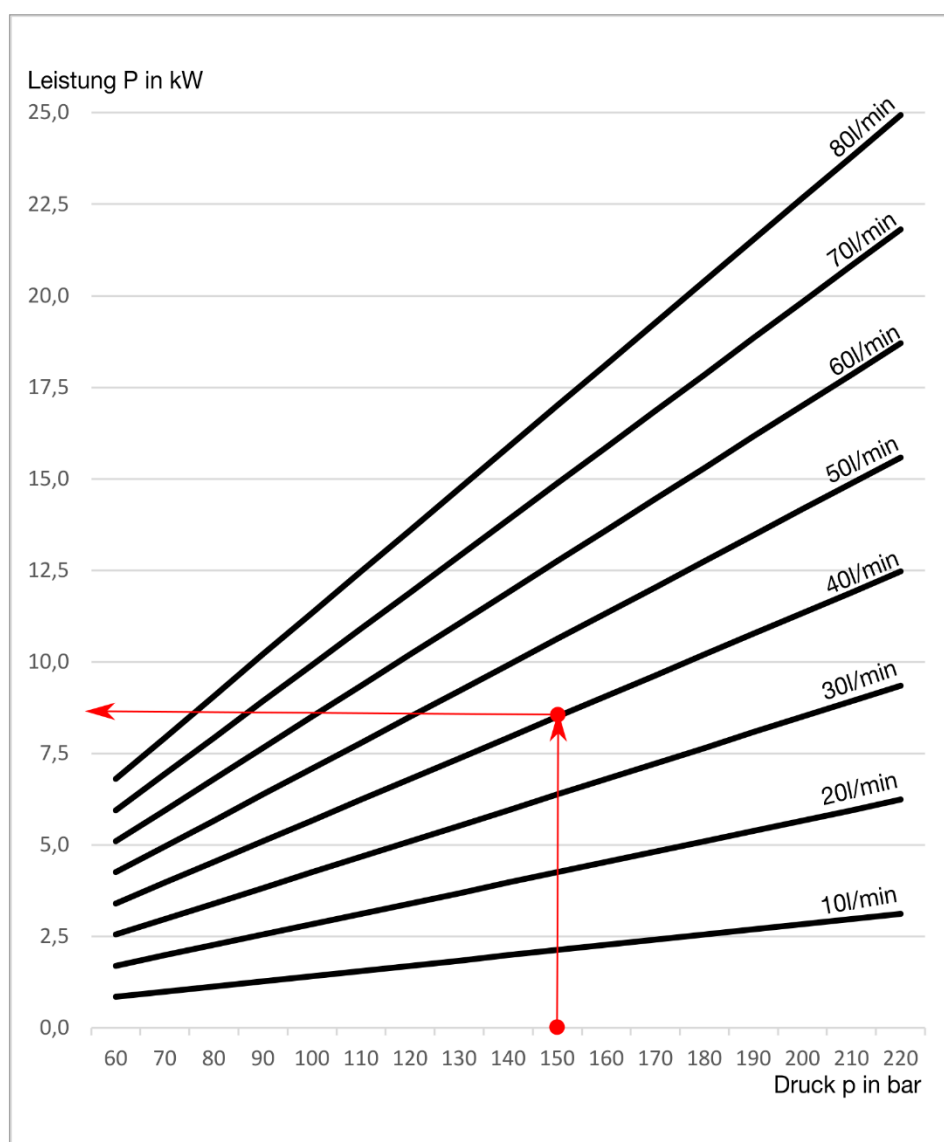

Fig. 2: Hydraulic power diagram



## 4 General safety notices

Guidelines and instructions that you must comply with when dealing with machines are presented in this section.

### 4.1 Presentation of the general safety notices

The safety notices used in the text employ pictograms and signal words, which in combination indicate the severity of the risk to be expected.



**Dangerous situations that can directly result in severe or fatal injuries.**



**Dangerous situations that can possibly result in minor injuries or material damage.**



**Recommendations or information for the operator. Read this note. It facilitates your work.**

### 4.2 Intended use



**To avoid misuse, also read section 6, Operation of the mower, all the way through.**

- The implements are designed for municipal tractors, i.e. carrier vehicles.
- They must only be operated on carrier vehicles with the power range specified in the technical data.
- Intended use also includes compliance with the operating, service, and maintenance conditions prescribed by the manufacturer.
- Moreover, intended use includes exclusive use of original spare parts and supplemental equipment, or use of such parts and equipment that meet the technical requirements specified by the manufacturer.
- Unauthorized modifications to the implements result in exclusion of liability on the part of the manufacturer.

#### **All other uses are excluded!**

Non-intended use causes:

- Danger of injury to the operator or third parties
- Carrier vehicle damage or implement damage
- Environmental damage

## 4.3 Instructions for the owner

### 4.3.1 Qualifications of personnel

Installation and maintenance tasks involving safety-relevant parts must only be executed by personnel with the following qualifications:

- They must have a technical education, such as agricultural machine mechanic, auto mechanic, etc.
- Persons without qualified training must be supervised by a person with qualified training.
- They must have read and understood this operating manual.
- They must be aware of the relevant safety regulations (accident prevention).

### 4.3.2 Accident prevention

The safety regulations and accident prevention regulations are legally regulated in every country. The workshop manager or the appointed specialist for occupational health and safety is responsible for compliance with the valid regulations.

### 4.3.3 Instruction

At transfer of the implement the owner receives instruction in the operation and maintenance of the implement from the sales partner.

The owner must ensure that operating and maintenance personnel have been instructed in full scope in the operation and maintenance of the implement.

## 4.4 Warning signs

Warning signs indicate hazards that cannot be countered through protective measures. To avoid severe or fatal injuries the warning signs must always be obeyed.



**Missing warning signs must be replaced without delay.  
Do not operate the implement if the warning signs are missing.  
You can order the warning signs by specifying the spare parts numbers listed in section 4.5.2 (no. V000...).**

### 4.4.1 General warning signs

In this section the non-specific, generally-valid warning signs are explained.



Read the operating manual and comply with the safety notices.



Prior to performing maintenance and repair tasks, turn off the engine and remove the key.



Injuries due to fluid escaping under high pressure. Comply with the notice in the operating manual.

### 4.4.2 Machine-specific notice

Machine-specific warning signs and instructions concerning operation and maintenance of the machine are explained in this section.



Danger due to ejected parts when the engine is running – maintain a safety distance!



Only touch machine parts after they have come to a complete standstill!



Do not open or remove protective devices when the engine is running.



During operation, maintain a sufficient distance to the mowing blade!



Implement is only suitable for a PTO shaft speed of 2000 rpm!  
Predominantly mid-mount, front, or independent engine PTO shafts.



Implement is only suitable for a PTO shaft speed of 1000 rpm!  
Usually an independent engine PTO shaft.

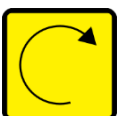

Implement is only suitable for clockwise PTO shaft rotation! (CW)

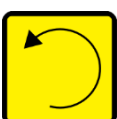

Implement is only suitable for counterclockwise PTO shaft rotation! (CCW)

The direction of rotation is always specified when viewing the end of the PTO shaft from the front (see Fig. 1 page 5).



Do not operate the mower without discharge guard or suction port!



After each use re-tighten all screws



Lubricating point

## 4.5 Safety devices

There are various safety devices on machines to protect people when working with a machine, or who are in the direct vicinity of the machine, to prevent premature wear, and also to prevent environmental damage. These safety devices are a fixed component of the machine and must not be manipulated or removed. Missing or damaged safety devices must be replaced without delay.

Concerning the safety devices, a distinction is made between protective devices that prevent contact with a danger point, and safety notices that alert to a hazard on the machine.

Likewise, hazards can occur through insufficient maintenance; consequently the maintenance instructions must also be classified as safety notices



Each time before starting to drive, ensure that all described safety notices and protective devices are completely present and functional. Do not operate the implement if safety notices or safety devices are missing or damaged.

#### 4.5.1 Protective device on the machine

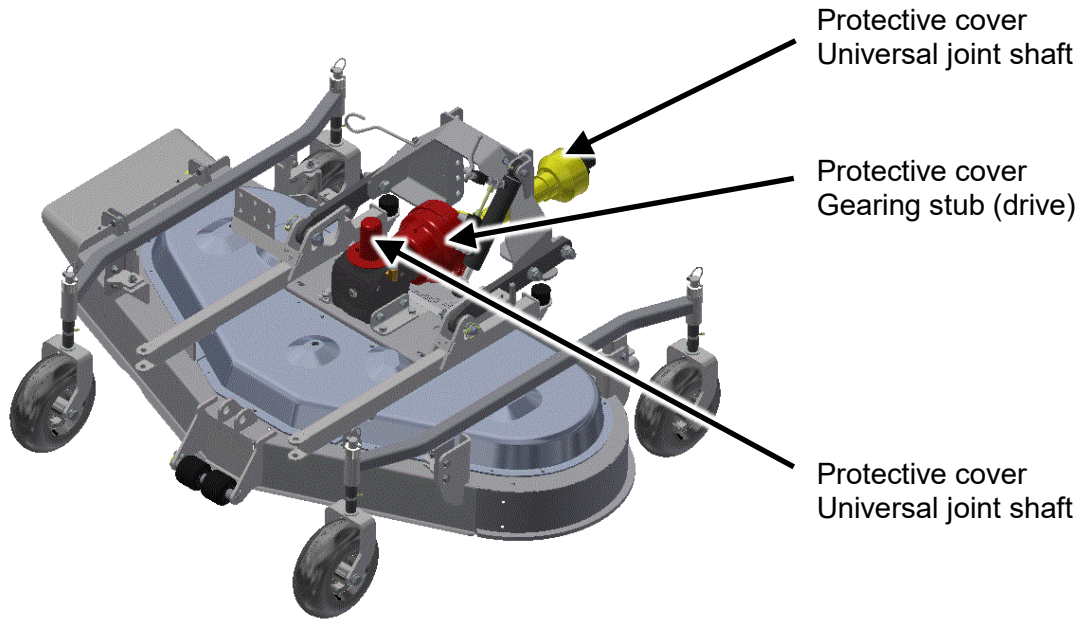

Fig. 3: Protective cover for gearbox

---

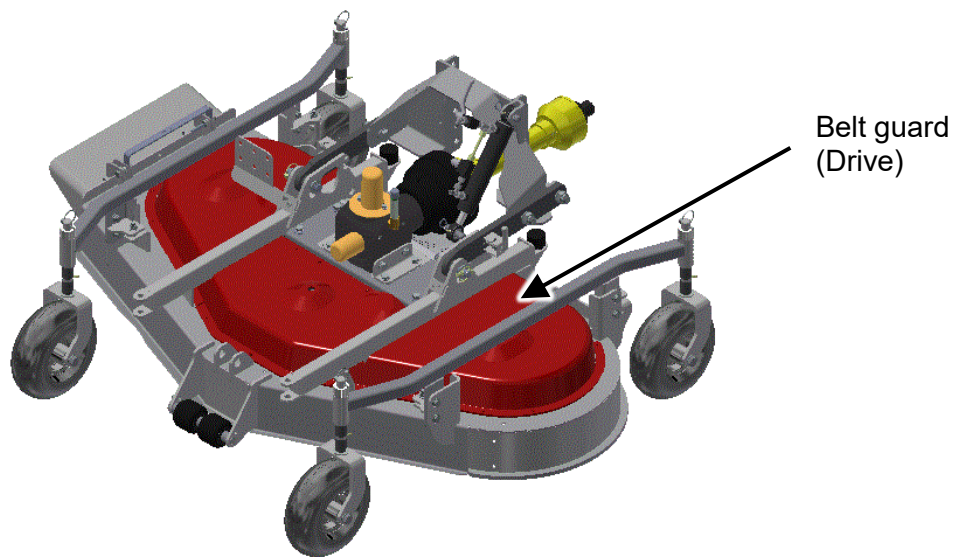

Fig. 4: Belt guard (drive)

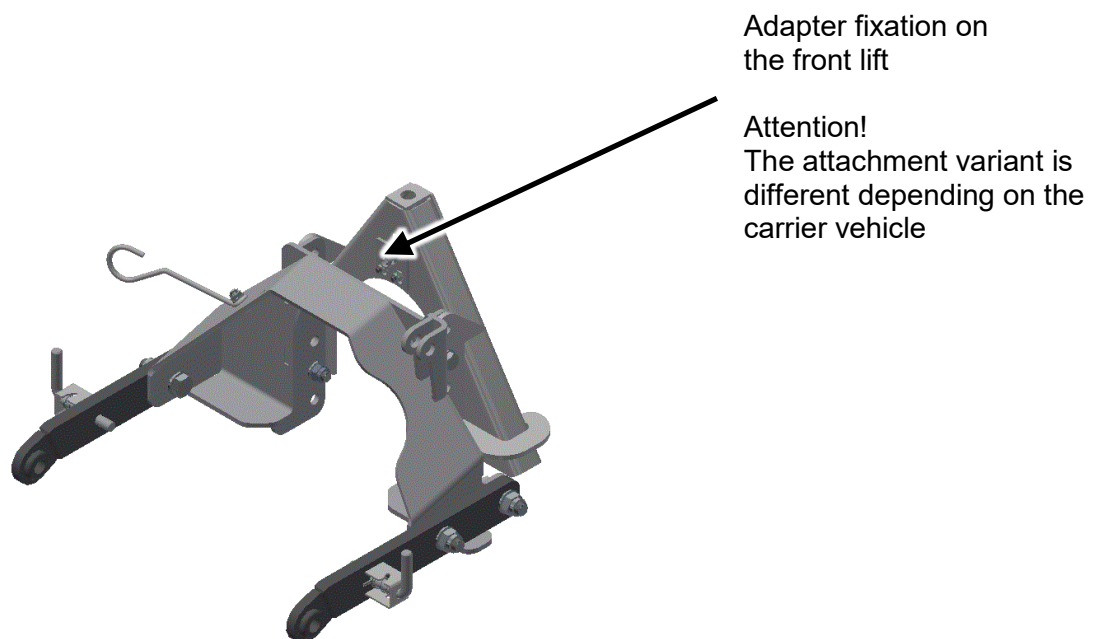

Fig. 5: Adapter fixation on the front lift

**Standard equipment:**  
Side discharge cover.

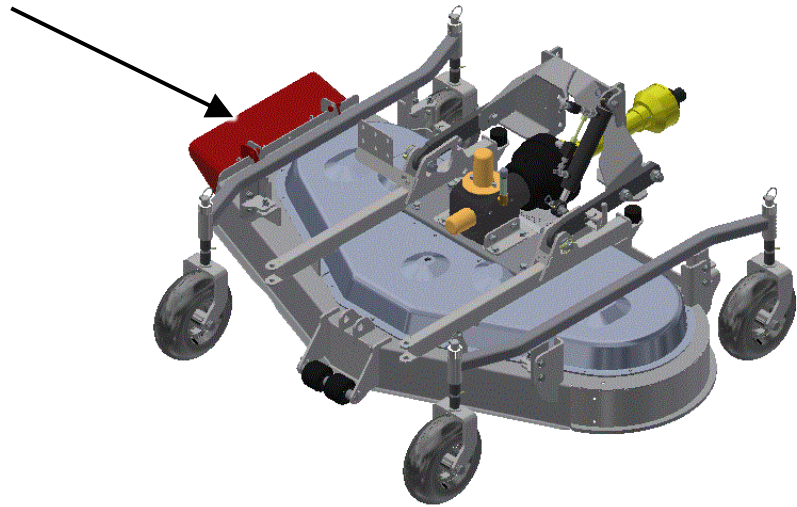

Fig. 6: Side discharge cover

---

**Optionally available:**  
Port with suction hose

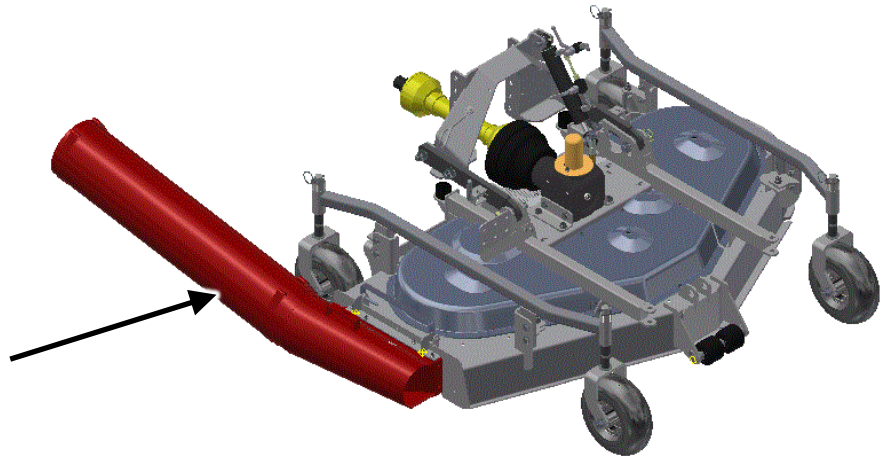

Fig. 7: Port with suction hose

---



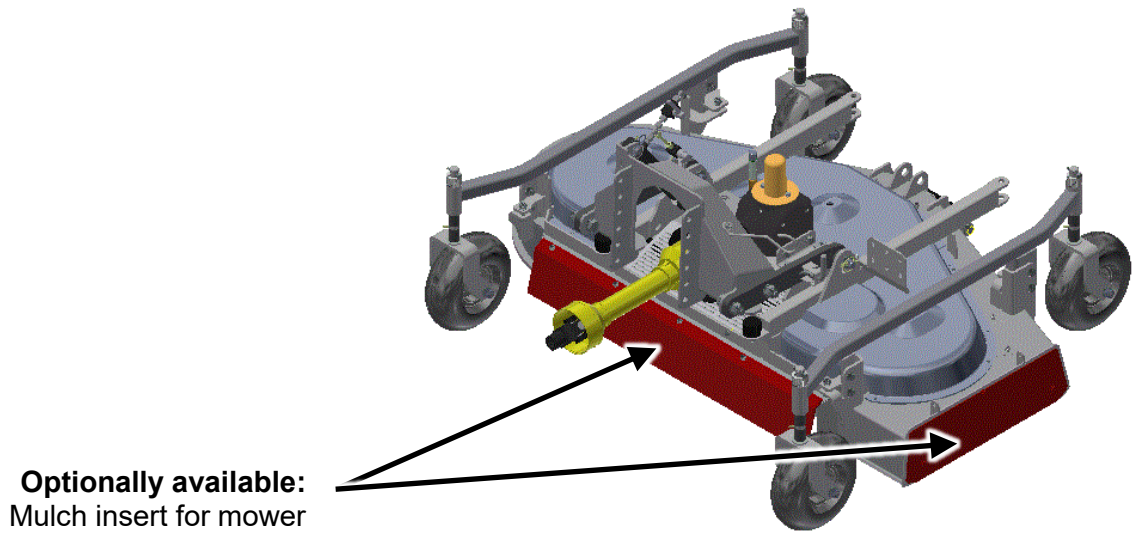

Fig. 8: Mulch insert for mower

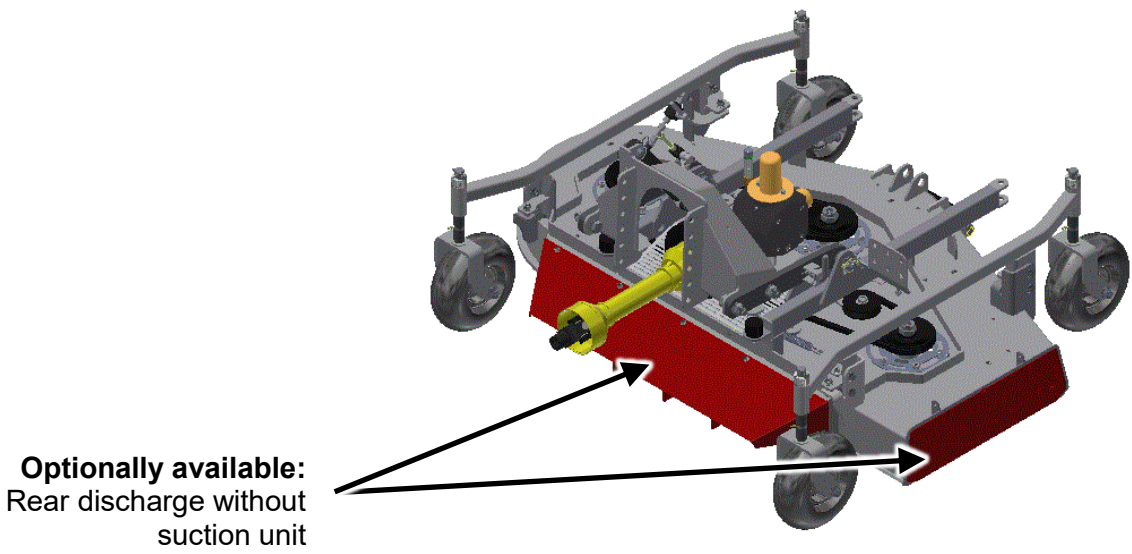

Fig. 9: Rear discharge without suction unit



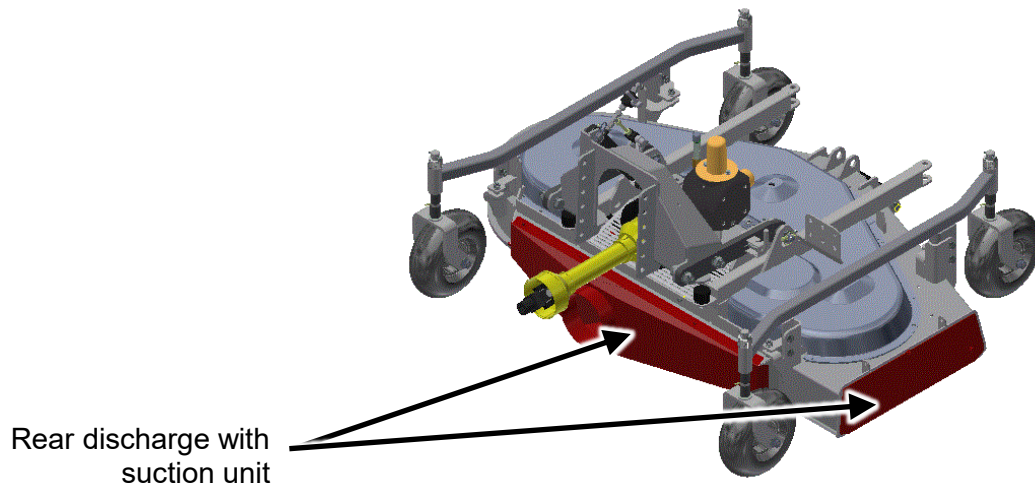

Fig. 10: Rear discharge with suction unit

---

#### 4.5.2 Safety notices on the machine



Attention  
After each use re-  
tighten all screws!  
Order no. V0 002 965

Read the safety in-  
structions  
Order no. V0 002 922

Switch off engine  
Order no. V0 002 925

Fig. 11: Warning sign on the right attachment bracket

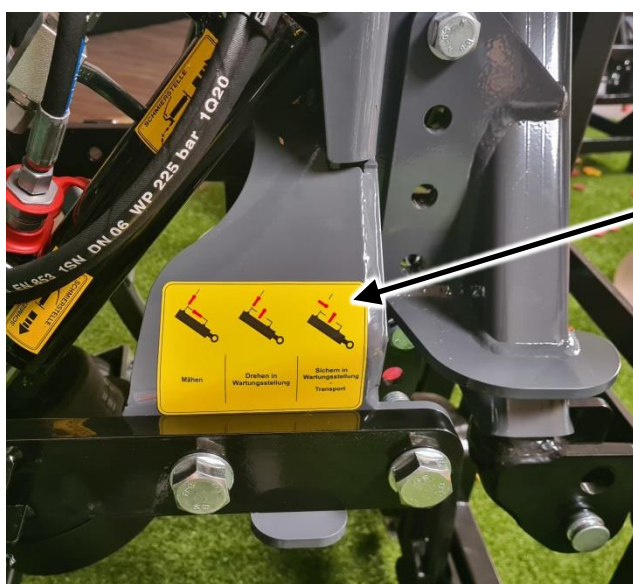

Lever position for  
maintenance position  
Order no. V0 002 966

Fig. 12: Warning sign on the left attachment bracket

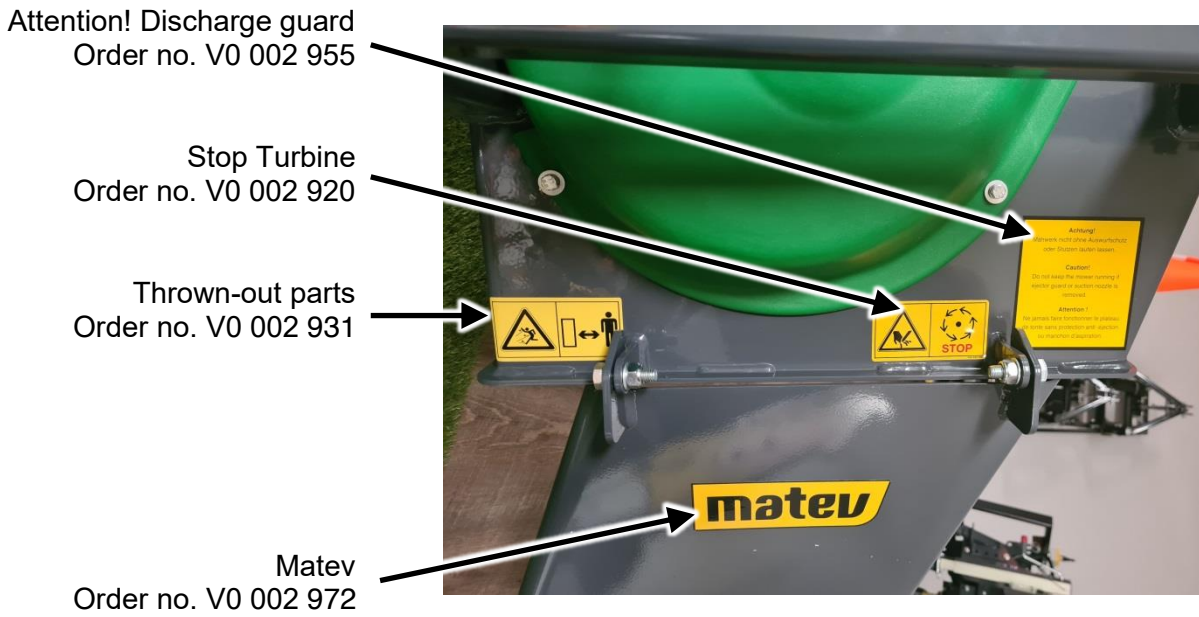

Fig. 13: Warning sign on the basic deck (right side discharge)

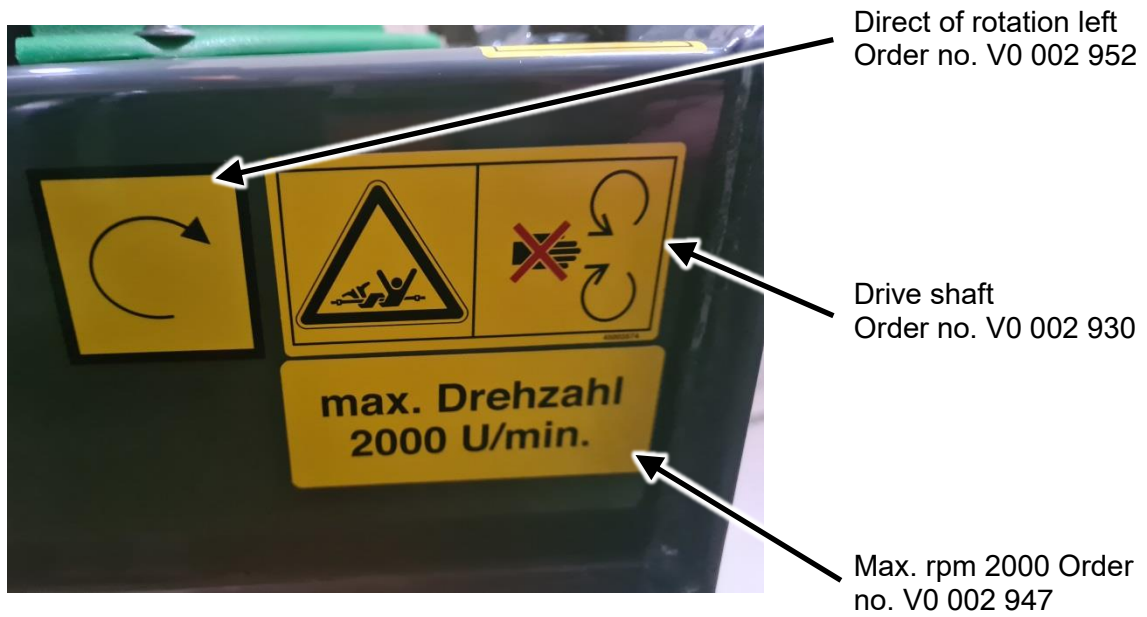

Fig. 14: Warning sign on the basic deck (right side discharge rear)

Mower blades  
Order no. V0 002 928



Fig. 15: Warning sign – mower blades





Do not remove protective  
device  
Order no. V0 002 924

Fig. 16: Warning signs

# 5

## 5 Equipmentvariants

### 5.1 Basic implements with rigid or hydraulic driving frame

	<p>Basic implement – rigid driving frame Available as MOW 140, MOW 160, MOW 190</p>
	<p>Basic implement with hydraulic driving frame Available as MOW 160</p>

### 5.2 Optionally required accessories



#### 5.2.1 Attachments

	<p>Attachment – Cat. 0 Cat. 0 available for MOW 140, MOW 160, MOW 190 Cat. 1N available for MOW 160, MOW 190 Cat. 1 available for MOW 160, MOW 190 Cat.1 available for MOW 160, MOW 190 Cat.1 available for MOW 160, MOW 190 Cat. 1 with quick catch hook available for MOW 160, MOW 190</p>
---	--



#### 5.2.2 Mower inserts

	<p>Side discharge mower insert Available for MOW 140, MOW 160</p>
---	---

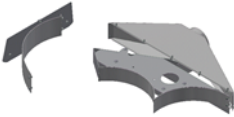

	<p>Rear discharge mower insert Available for MOW 140, MOW 160</p>
	<p>Mulch insert for mower Available for MOW 140, MOW 160</p>
	<p>Rear discharge with suction unit Available for MOW 160</p>

### 5.2.3 Drive kits

	<p>Mechanical drive 1000 rpm CW/CCW, and 2000 rpm, CW/CCW Available for MOW 140, MOW 160, MOW 190</p>
	<p>Gearbox booster kit Available for MOW 160</p> <p>Required when the tractor-side distance between PTO shaft and ground is greater than 400 mm at 2000 rpm, or greater than 500 mm at 1000 rpm.</p>

# 5

---



Hydraulic drive  
Available for MOW 160, MOW 190

## 5.3 Required accessories



Cover, colored  
Possible colors: yellow, green, blue, red, gray.  
Available for MOW 140, MOW 160, MOW 190

## 5.4 Optional accessories



Hydraulic front lift for maintenance position  
(Hydraulic connections are required)  
Available for MOW 140, MOW 160, MOW 190

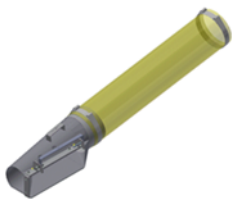

Port with suction hose  
Available for MOW 140, MOW 160, MOW 190



 A metal harrow unit with multiple tines, shown in a folded transport position. It has a central pivot point and hydraulic connection points.	<p>Harrow unit can be folded into transport position (Hydraulic connections are required) Available for MOW 160</p>
 An electromagnetic changeover valve with four hydraulic lines extending from it. The lines are black with green and red fittings.	<p>Electromagnetic changeover valve enables control of two hydraulic functions on the mower Available for MOW 160</p>

Fig. 17: Optional accessories



## 6 Operation of the mower

### 6.1 Application area

The mower is used for mowing green areas and agricultural areas.

The area of application extends from manicured lawns, to matted grass to uncultivated land.

### 6.2 Function

The mower works with three rotating blades, these blades are powered by the tractor via the working hydraulics.

- Use as rotary mower with side discharge:  
Through the rotating blades the grass is cut and the cuttings are laterally accelerated out of the rotary mower.
- If the mower is operated in conjunction with a suction unit and collection container the cuttings can be collected simultaneously.  
Appropriate devices are available on request.
- Use as rotary mower with rear discharge:  
Through the rotating blades the grass is cut and the cuttings are accelerated out of the rotary mower to the rear.
- Use of the mower with harrow unit:  
The harrow is used for mechanical weed removal and to loosen sod.

### 6.3 Instructions for mowing

#### 6.3.1 Clean the work terrain before mowing



Fig. 18: Clean the work terrain



**Ensure for yourself that the work area is free of objects that can damage the mower or the blades, or that could be thrown out (ejected) by the mower.**

### 6.3.2 Mowing irregular areas

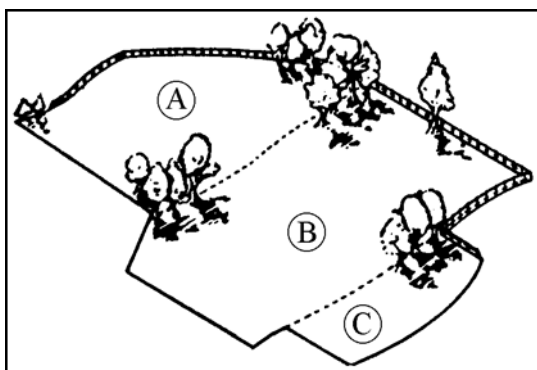

Fig. 19: Irregular areas

Divide irregular areas into smaller sections.  
Change the mowing pattern frequently; do not always work in the same pattern.

### 6.3.3 Mowing large areas

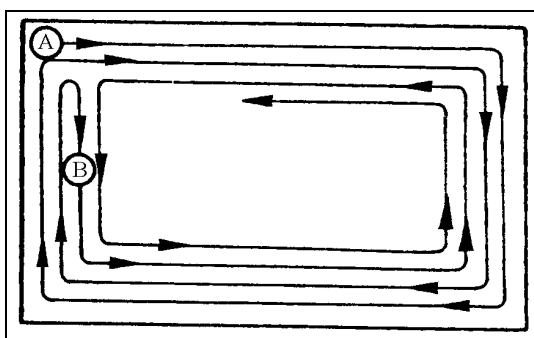

Fig. 20: Mowing large areas

Mow large free areas as shown on Fig. 20.

### 6.3.4 Mowing small areas

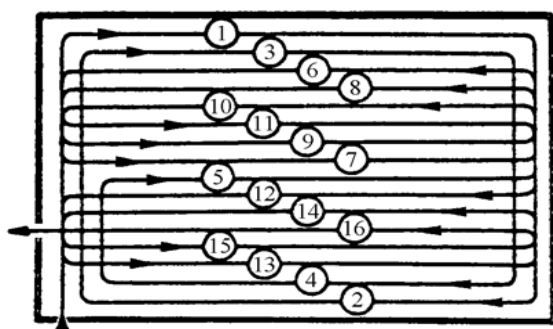

Fig. 21: Mowing small areas

If you do not use a collection container, mow small areas as shown in Fig. 21 – two to three rounds clockwise, the rest counterclockwise. This prevents the mower from repeated clogging due to accumulated cuttings.

## 7 Installation



Switch off the carrier vehicle and remove the ignition key before mounting or dismounting the mower



Prior to mounting on the tractor, ensure that the PTO shaft rpm, and the PTO shaft direction of rotation agree with the information on the mower.

### 7.1 Mounting the mower on the carrier vehicle

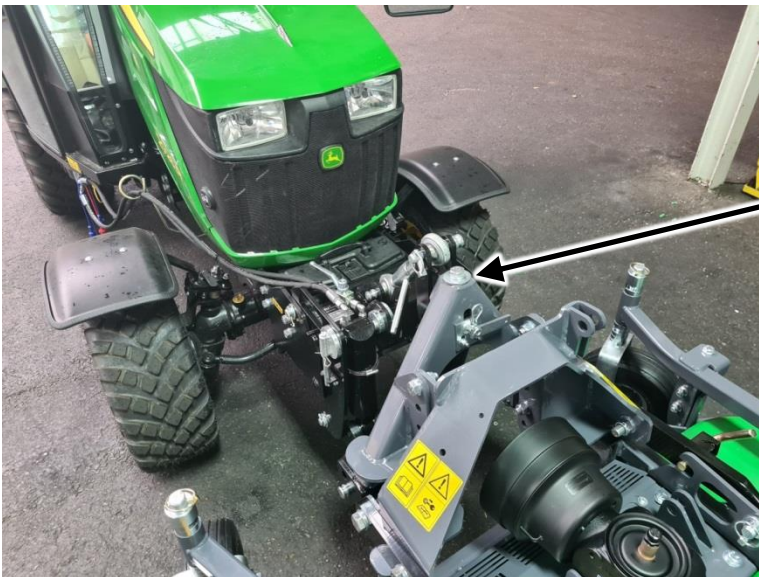

Fastening screw on the coupling support

Fig. 22: Mounting the mower on the carrier vehicle

The following optional attachment possibilities are available for the mower

- Attachment – Cat. 0
- Cat 1 attachment
- Attachment – Cat. 1 quick-catch hooks
- Attachment – ScanFrame
- For carrier vehicles without coupling support, see: The operating manual for the carrier vehicle.

For Cat. 0, Cat. 1, and ScanFrame the mower is hooked into the coupling triangle and fastened on the coupling support with the aid of the fastening screw.

For Cat. 1 quick-catch hooks, the lower link of the front power system is positioned relative to the mower in such a manner that when lifting out, the quick-catch hooks take up the lower links of the attachment.

Subsequently the upper link is fastened on the mower.

## 7.2 Mower with mechanical drive



**For attachment and removal: Always switch off the tractor engine and remove the ignition key.**



**Only use the provided material. Comply with the instructions in the operating manual (assembly instructions) provided by the manufacturer of the universal joint shaft. The universal joint shaft must be matched to the respective carrier vehicle.**



**Depending on the carrier vehicle, the provided universal joint shaft may be too long. Execute the steps described in the original manual of the manufacturer of the universal joint shaft, for shortening and mounting the universal joint shaft. If the manual has been lost or is no longer present for some other reason, contact matev GmbH.**



**The mower must be matched to the speed of the carrier vehicle's PTO shaft.**

## 7.3 Mowers with hydraulic drive

- Connect the 3 hydraulic hoses (flow, return, and the leak oil line) to the vehicle.
- Place the front hydraulics in float position.
- Switch-on the mower briefly.
- Check the direction of rotation of the blades. The blades must rotate clockwise (as viewed from above).



**Never reach into the mower when the blades are rotating. Switch off the tractor and remove the ignition key before reaching into the mower. Attention: The mower blades continue to rotate after the engine is switched off. Wait until the blades have come to a complete standstill before reaching into the mower unit.**

## 7.4 Mounting the port with suction hose on the mower

The suction port is only required, if for example, a grass collection device is used.

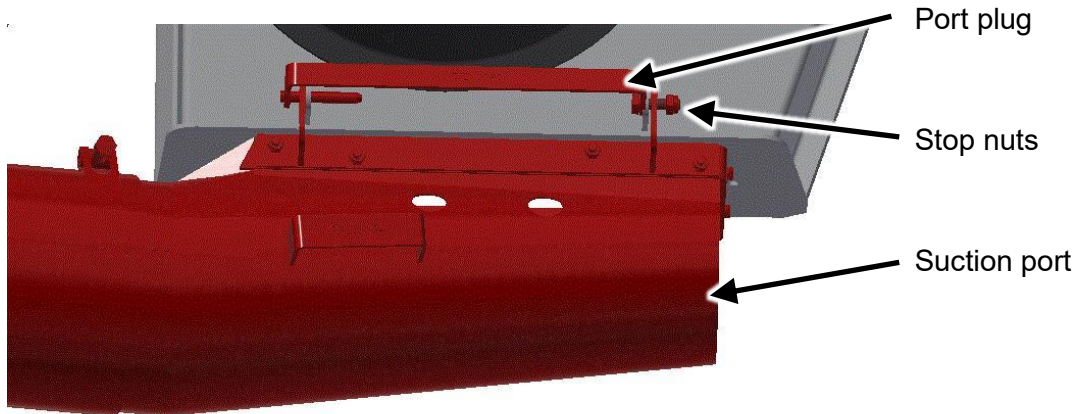

Fig. 23: Suction port

1. Hold the suction port with the hinge strip on the mower discharge.
2. Connect the suction port to the port connector on the mower.
3. Secure the port connector with the provided stop nuts.



**The suction port simultaneously serves as protection against rock impact. In accordance with the Machinery Directive, it must not be possible to detach the protective devices without tools. Do not forget to secure the port connector with the aid of the stop nuts.**



**If you use the side discharge without suction port, you must mount the rock guard on the mower, secure it with the stop nuts and swing it down. Do not use the side discharge without rock guard (Fig. 24).**

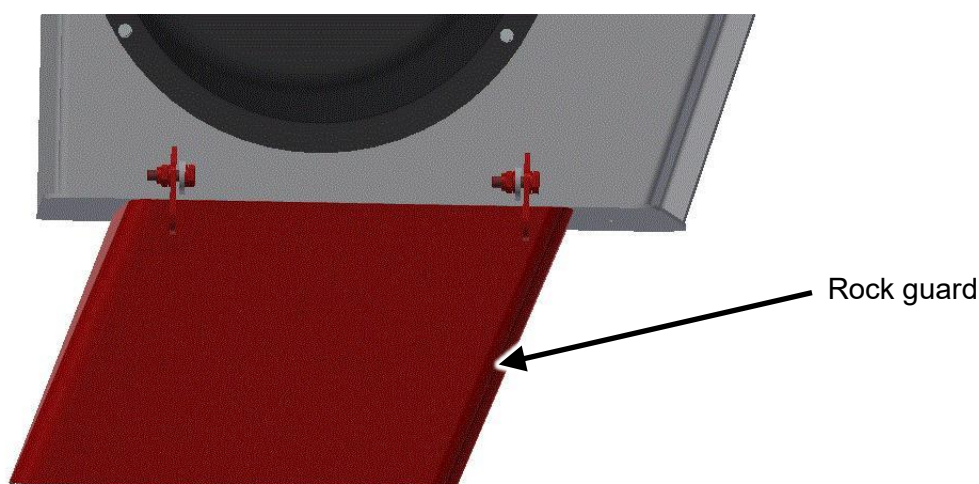

Fig. 24: Rock guard on side ejection

## 7.5 Operation of the mower



**Before first use of the mower, comply with the instructions on safety and handling for operation of the entire implement and the connection to the carrier vehicle.**



**When mowing, always switch the carrier vehicle's front lift to float position. The mower must rest on the four casters. Adjust the cutting height via the casters. Excessive distance to the ground can result in solid objects being ejected from the mower.**



**Adapt the drive speed for the grass to be mowed or for the cutting height and cutting quantity. Recommended drive speed is between 3 and 8 km/h.**



**The cutting pattern depends on many factors:  
Grass characteristics: Grass height, grass density, grass types, and wetness of the grass, drive speed, and cutting height.**



**Never reach into the mower when the blades are rotating. Switch off the tractor and remove the ignition key before reaching into the mower. Attention: The mower blades continue to rotate after the engine is switched off. Wait until the blades have come to a complete standstill before reaching into the mower unit.**





Ensure for yourself that no one is in the work area.



For road travel, the mower must be lifted out and the locking bolt must be secured against swinging.  
For the hydraulic maintenance position (optionally available) the mower can be secured via the shut-off valve and additionally secured with the locking bolt.

## 7.6 Secure the mower for road travel to the work site



The mower must be safeguarded from swinging for road travel to the work site.

To do this proceed as follows:

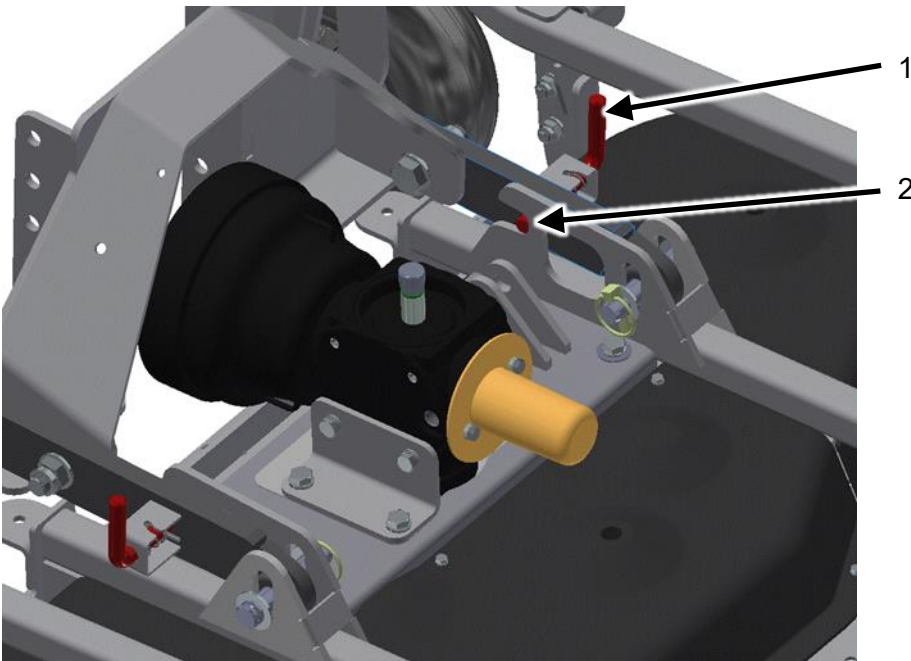

Fig. 25: Safeguard with locking pin

Turn bolt 1 clockwise, until it locks in the arrest plate 2.

Secure the mower with hydraulic lift-out for maintenance position (optionally available)

To do this proceed as follows:

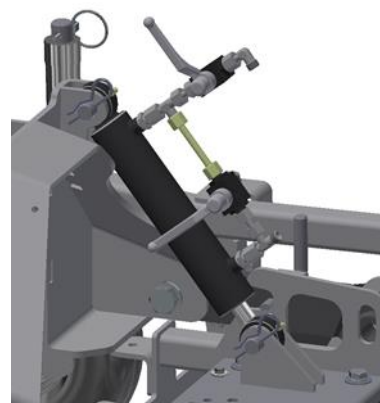

Fig. 26: Transport position

Set the shut-off valves to "Transport", as shown in Fig. 26

## 7.7 Adjusting the mower incline



**The driving frame is inclined forward in the factory.  
The driving frame should also be left this way! Or after a change, it should be returned to this position.**

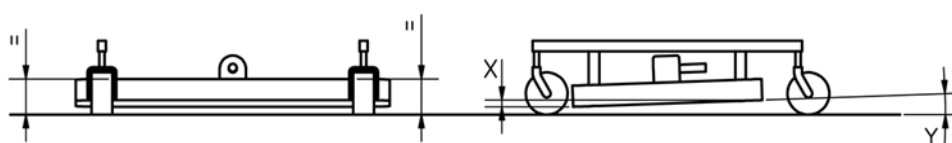

Fig. 27: Adjusting the inclination on the mower



### 7.7.1 Adjusting the inclination angle on the driving frame

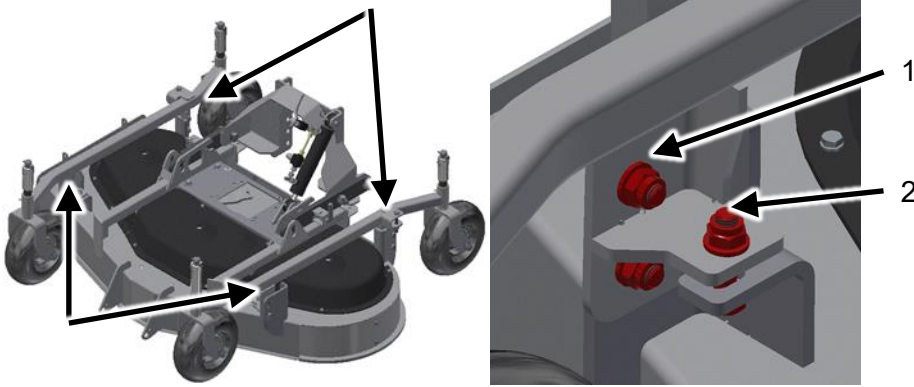

Fig. 28: Adjusting the inclination angle on the driving frame



**To align the mower, do not tighten the fastening screws, otherwise the mower cannot align itself**

The mower can be appropriately "lifted up" or "lowered" by means of the two adjusting screws 2 on each side.

Unscrew fastening screws 1 and adjust accordingly with adjustment screw 2.

The angle forward inclination should be  $1^\circ$  (5-10 mm).



**To align the mower, as the reference for alignment always measure at the blades with a suitable measuring tool.**

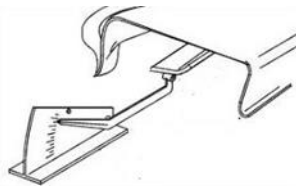

Fig. 29: Measuring tool

## 7.8 Adjusting the cutting height for the rigid driving frame



The four casters must be adjusted uniformly.

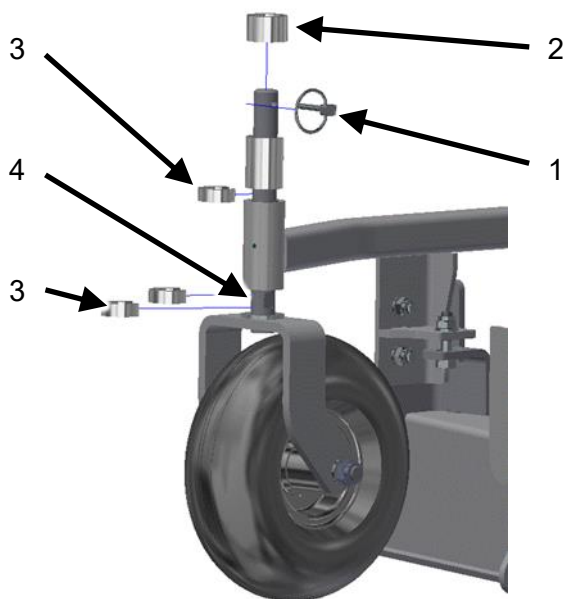

Fig. 30: Caster on the mower

1. Lift out the mower with the aid of the front power system, until there is an adequate distance between the casters and the ground.
2. Hold the caster firmly and remove the linch pin 1.
3. Remove the spacer ring 2.
4. Pull the caster downward slightly.  
Pull out the required number of spacer rings 3 from the lower flattened surface 4, and fit them on again on top. Or remove the required number of spacer rings 3 from above and slide them back in at the flattened position 4.
5. Re-secure the caster with the linch pin 1.
6. Repeat instructions 1 - 6 on the other three casters.
7. Each spacer ring changes the cutting height by 13 mm (0.5 inch)

## 7.9 Adjusting the cutting height on the hydraulic frame



**Caution – moving parts.**  
Prior to changing the cutting height, ensure that no one is on the mower

The mower is set to the desired cutting height by means of a hydraulic cylinder

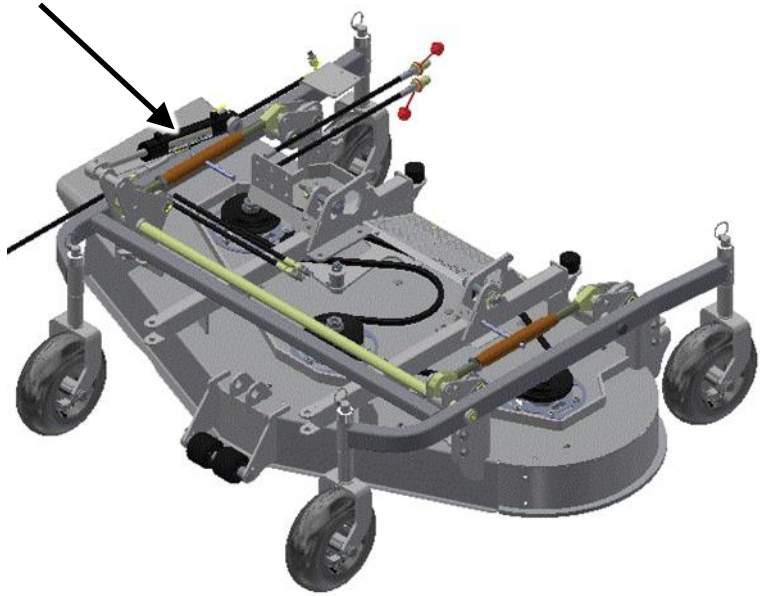

Fig. 31: Hydraulic frame

The scale shows the cutting height.

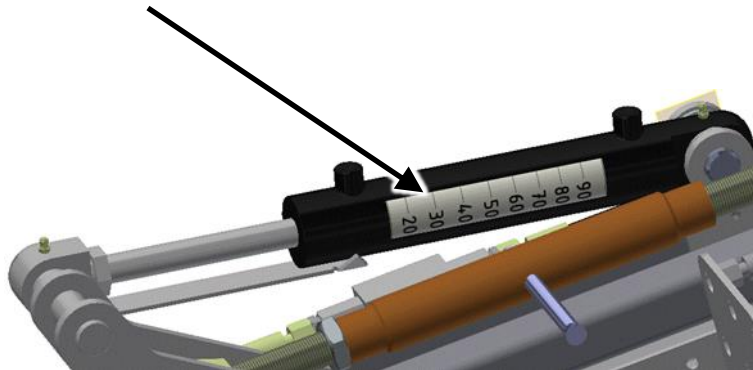

Fig. 32: Scale on the cylinder

## 7.10 Moving the mower into maintenance position



The mower must not be switched on in maintenance position. Switch off the engine and remove the ignition key, after the mower has been brought into maintenance position.



**Caution – moving parts.**  
Before moving the mower into maintenance position, or back into operating position, ensure that no one is on the mower.

1. With mechanical drive, the universal joint shaft must be removed.
2. If a suction unit is present, the suction hose must be removed.
3. Lift out the mower with the front power lifter.
4. Move the shut-off valves to the "Turn in maintenance position".



Fig. 33: The shut-off valves "Turn in maintenance position"

5. Turn the casters 180°.

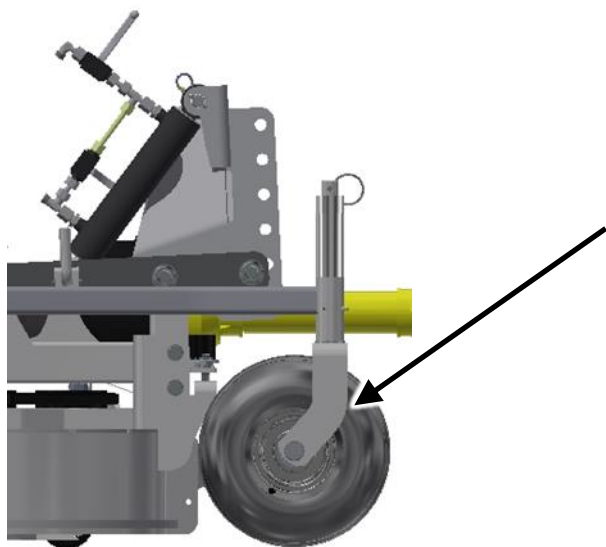

Fig. 34: Position of the wheels for maintenance position

6. Move the mower into maintenance position.



Fig. 35: Mower in maintenance position

7. Move the shut-off valves to the "Secure in maintenance position".



Fig. 36: The shut-off valves "Secure in maintenance position"



**Attention, life-threatening danger**

The mower must not be switched on in maintenance position. Switch off the engine and remove the ignition key, after the mower has been brought into maintenance position.

8. Executing maintenance tasks



Before moving the mower back into operating position, ensure that no one is on the mower.

9. Move the shut-off valves to "Turn in maintenance position"
10. Start the tractor and move the mower into horizontal position
11. Turn the shut-off valves back to the desired position; "Transport" or "Mow"

## 7.11 Adjusting the air supply

For a clean flow of grass it is important that sufficient air can flow into the mower. The intake air is accelerated through the mower discharge together with the cut grass. This is the only way to exclude the possibility of clogs in the mower or in the suction port.

As a rule, air is supplied through the gap between the ground and the mower. When mowing extremely dense grass with a low cutting height, the gap between the sod and the mower is minimal. In this case not much air can flow into the mower and the grass flow worsens.

To optimally mow even in dense grass and with a low cutting height, the mower has three air regulating disks. These are arranged centrally around the blade units. When opening the air regulating disks, air from above can flow into the mower and thus ensure a better grass flow.

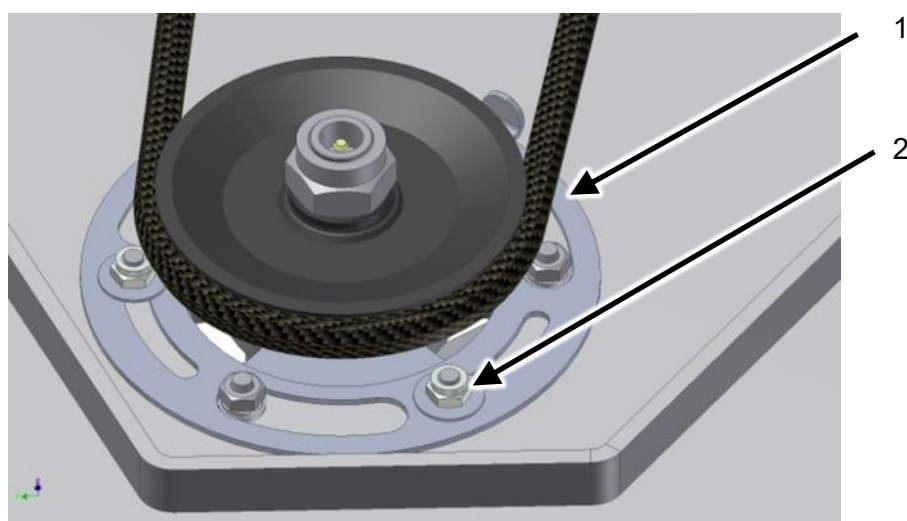

Fig. 37: Adjusting the air intake

1. Dismount the belt guards
2. Unscrew the fastening nuts 2 of air regulating disks 1.
3. Turn the air regulating disks 1, in such a manner that the air openings on the disk are aligned with the air openings on the bearing bracket.
4. Retighten the fastening nuts 2 of the air regulating disks 1
5. Mount the belt cover.



**Do not operate the mower if the belt guards are missing or damaged.**

## 7.12 Securing the lawn harrow for road travel to the work site



**For road travel to the work site, the lawn harrow must be prevented from unfolding**

To do this proceed as follows:

1. Completely lift out the lawn harrow.
2. Push the harrow back, counter to the direction of travel (beyond the dead point).
3. Insert lock bolt 1 and secure it axially with the linch pin.

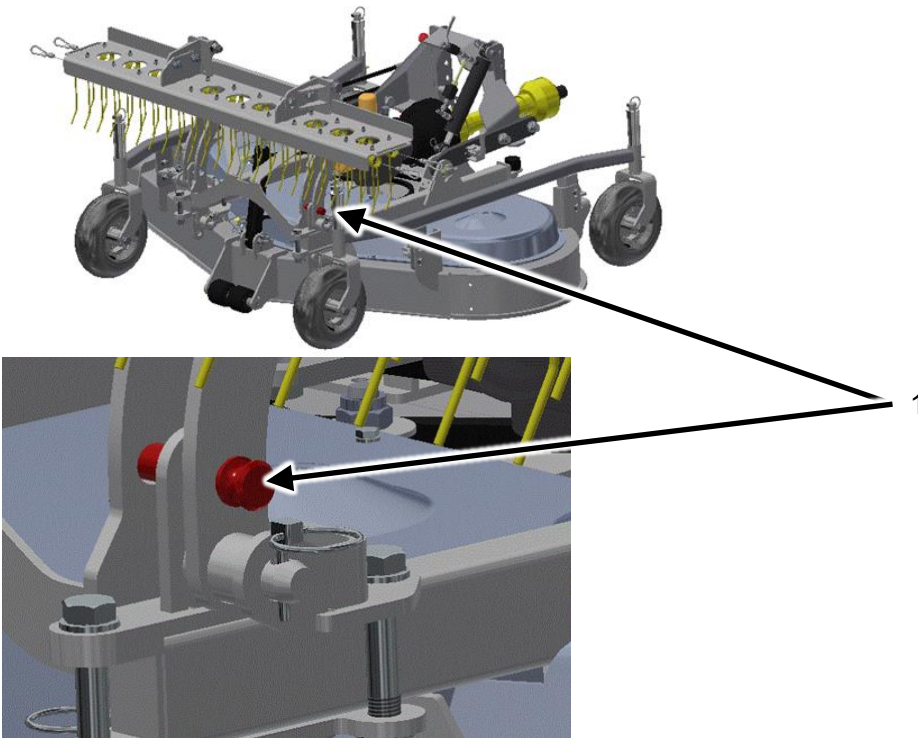

Fig. 38: Transport position of the harrow



**The hydraulic cylinder must not be activated in transport position. Otherwise the lawn harrow will be damaged.**

## 7.13 Move the lawn harrow into transport position.

1. Pull out the lock bolt 1.
2. Pull the harrow in the direction of travel all the way to the stop



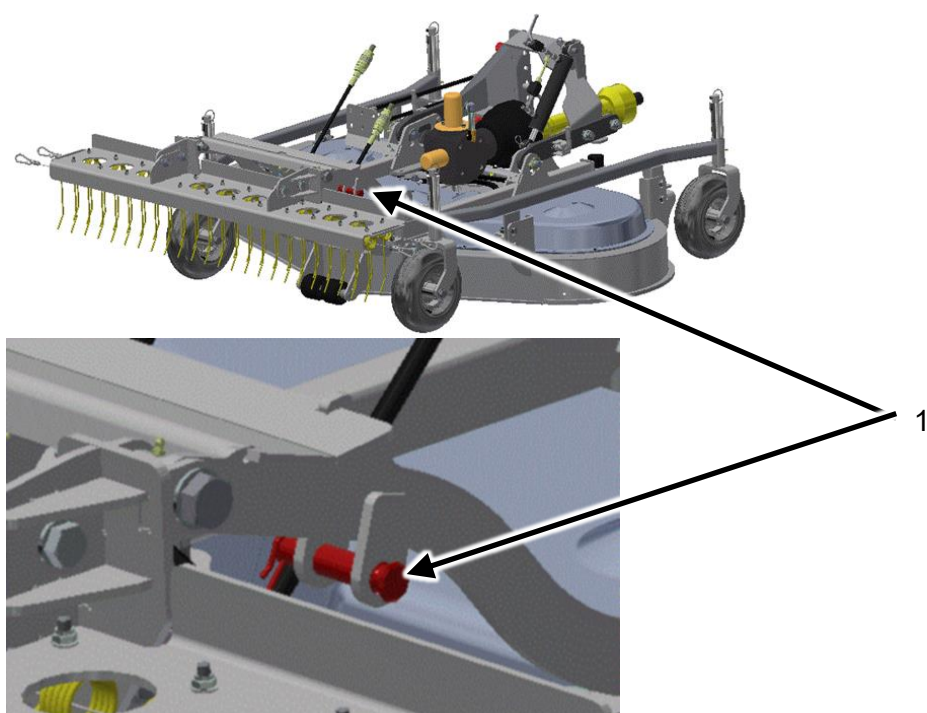

Fig. 39: Harrow position in operation

3. Insert the lock bolt 1 underneath the rake and secure it axially with the linch pin.



**The lock bolt must be mounted in work position, as shown in Fig. 39.  
Without the lock bolt the rake can swing down due to bumps in the ground**



### 7.13.1 Adjusting the angle of inclination of the tines.

The angle of inclination can be adjusted upward or downward by approx. 10 degrees.

1. Unscrew screws 1.
2. Adjust the angle of inclination.
3. Tighten screws 1.

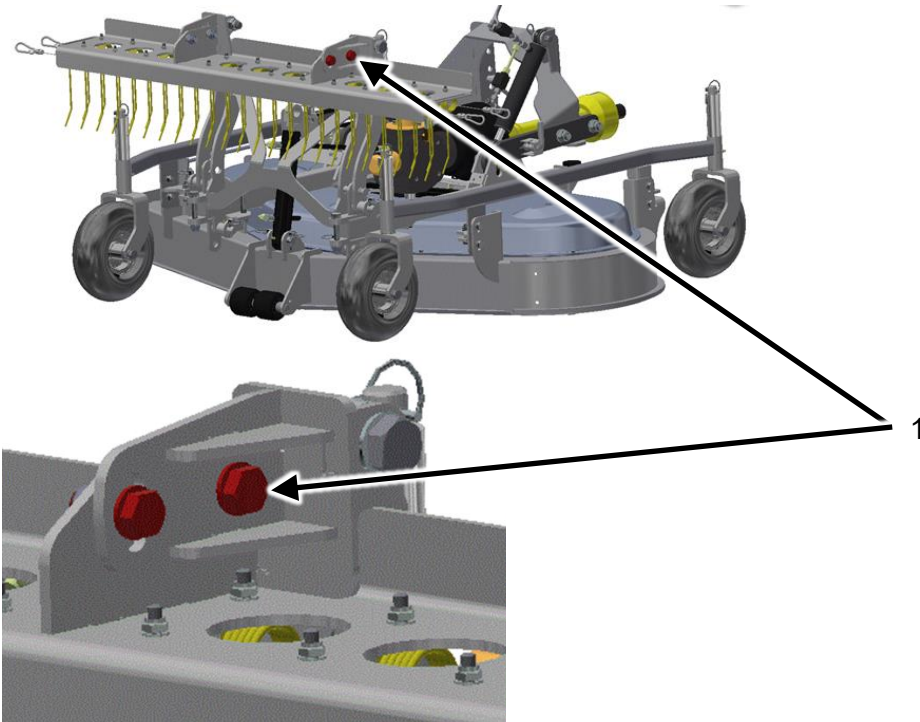

Fig. 40: Adjusting the angle of inclination of the tines.

### 7.13.2 Changing the plunge depth of the tines

The harrow must be adapted to the respective cutting height for an optimal plunge depth of the tines. This is achieved with the aid of the stroke limitation when retracting the cylinder.



**Improper adjustment of the tine plunge depth into the ground can damage the sod.**

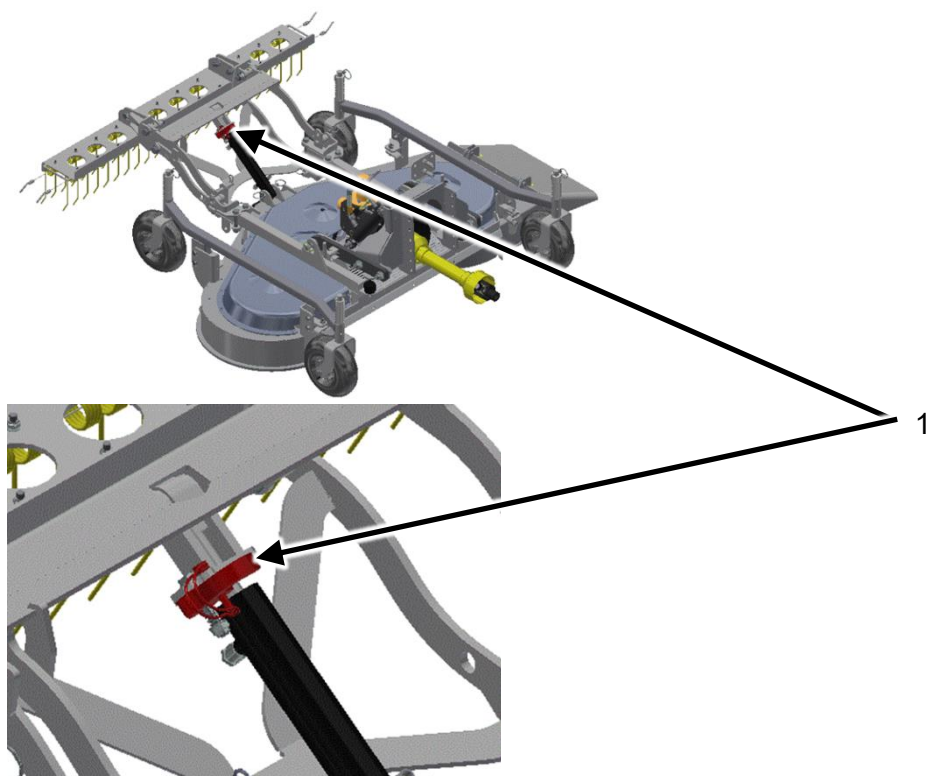

Fig. 41: Stroke limitation

Cutting height range	Cutting height adjustment on the rigid driving frame, see section 7.8 Number of spacer rings:	Recommended number of disks in the stroke limitation (Plunge depth of the tines)
28 - 36 mm	0	4
36 - 48 mm	1	3
48 - 58 mm	2	2
58 - 69 mm	3	1
69 - 80 mm	4	0

## 8 Maintenance

### 8.1 Safety when performing maintenance



**Personal injury or tractor and implement damage can occur. Before each use of the implements check all safety-relevant parts and the hydraulic connections.**



**The mower must not be switched on when maintenance tasks are performed. Switch off the carrier vehicle engine and remove the ignition key.**



**Danger of crushing due to moving parts. Never reach into the crushing hazard zone if parts are moving or can move.**



**Wear suitable protective clothing when changing the Mower blades.**



**Properly reattach all protective devices that have been dismantled after executing the maintenance tasks.**



**After the first 20 hours of operation check all screw and bolt connections. Subject the implement to regular maintenance. Use lubricating grease to lubricate the moving parts. See Lubrication schedule.**

### 8.2 Maintenance

The moving parts of the implement must be greased or oiled at regular intervals, and always at the beginning and end of the season.

#### 8.2.1 Daily maintenance tasks

- Clean the machine after each use.
- Each time before starting to drive, ensure that all described safety notices and safety devices are completely present and functional.
- Check hydraulic connections and hoses for leaks.
- Check wear parts, such as blades, and replace them or have them replaced as needed.
- Retighten the fastening screws of the blades, possibly with 250 Nm.
- Check tire pressure; tire pressure must be 1.5 bar.

### 8.2.2 Weekly maintenance tasks or after 25 operating hours.

- Check all screw connections and bolt connections. Tighten any loose screws, and secure any loose bolt connections with spring cotter pins. Visually inspect the belt; worn or damaged belts must be replaced.

### 8.2.3 Mower blades

The blades are wear parts and must be sharpened and balanced regularly.



**Wear suitable protective equipment for installation and removal of the mower blades.**



**If the blade is deformed by an object, a rock for example, the blade must be replaced without delay. Do not continue to operate the mower with the damaged blade.**

### 8.2.4 Mounting the V-belt

If you must replace the V-belt, when mounting, ensure that the belt runs correctly in its course.

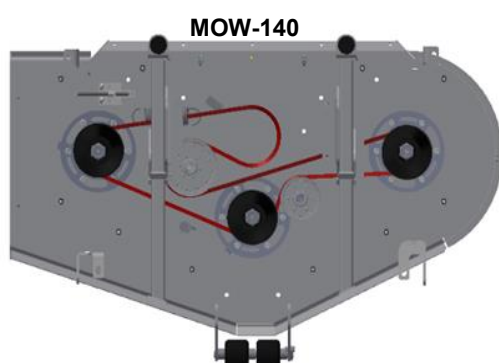

Fig. 42: V-belt run for the MOW 140

MOW-160

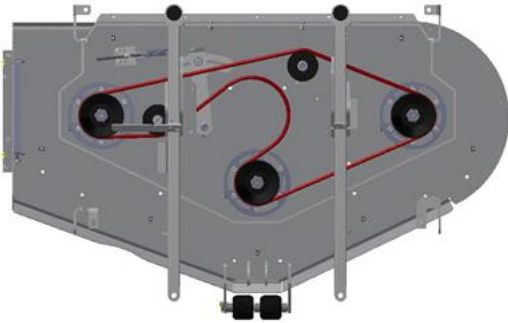

Fig. 43: V-belt run for the MOW 160

MOW-190

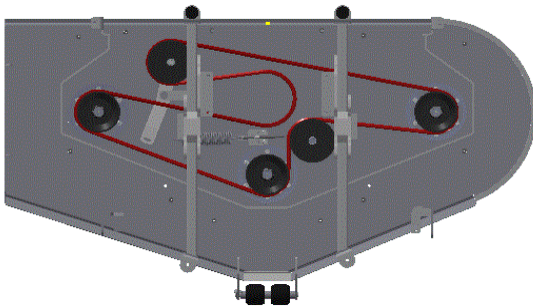

Fig. 44: V-belt run for the MOW 190



The springs of the tension pulleys are under tension. Ensure that both ends of the springs are hooked in correctly. After replacing the belt, it may be necessary to re-adjust (re-tension) the belt.



Do not operate the mower if the belt guards are missing or damaged.

### 8.3 Cleaning and care

To ensure the function of the mower, you must clean grass clippings off of the mower after each use.



Cleaning tasks, e.g. with a high-pressure cleaner, should be executed in such a manner that the water jet is not aimed directly at bearing parts and turned parts (shaft seals, lubricating nipples, etc.).

After cleaning the mower, check moving parts for ease of movement, regrease if necessary (see section 8.4).

## 8.4 Lubricating schedule

At regular intervals (every 30 operating hours) and always at the beginning and end of the season, the moving parts of the implement must be greased or oiled.

Check the fill level of the gearbox every 30 operating hours; replace the oil after 1,000 operating hours.

Grease the marked points with a grease gun as specified in the lubrication schedule.



Symbol	Meaning
1/d	Lubricate daily
1/30 h	Lubricate every 30 operating hours
2/a (1/500 h)	Lubricate at the beginning and end of the season and after 500 operating hours
	Use a grease gun
	Check oil level, top-up oil if necessary Change the oil after every X operating hours
	Please comply with the operating manual provided for this component. The lubricating intervals are specified in the operating manual

Table 2: Lubrication schedule symbols

## 8.4.1 Maintenance schedule for the mower



## 8.4.2 Maintenance schedule for the mower

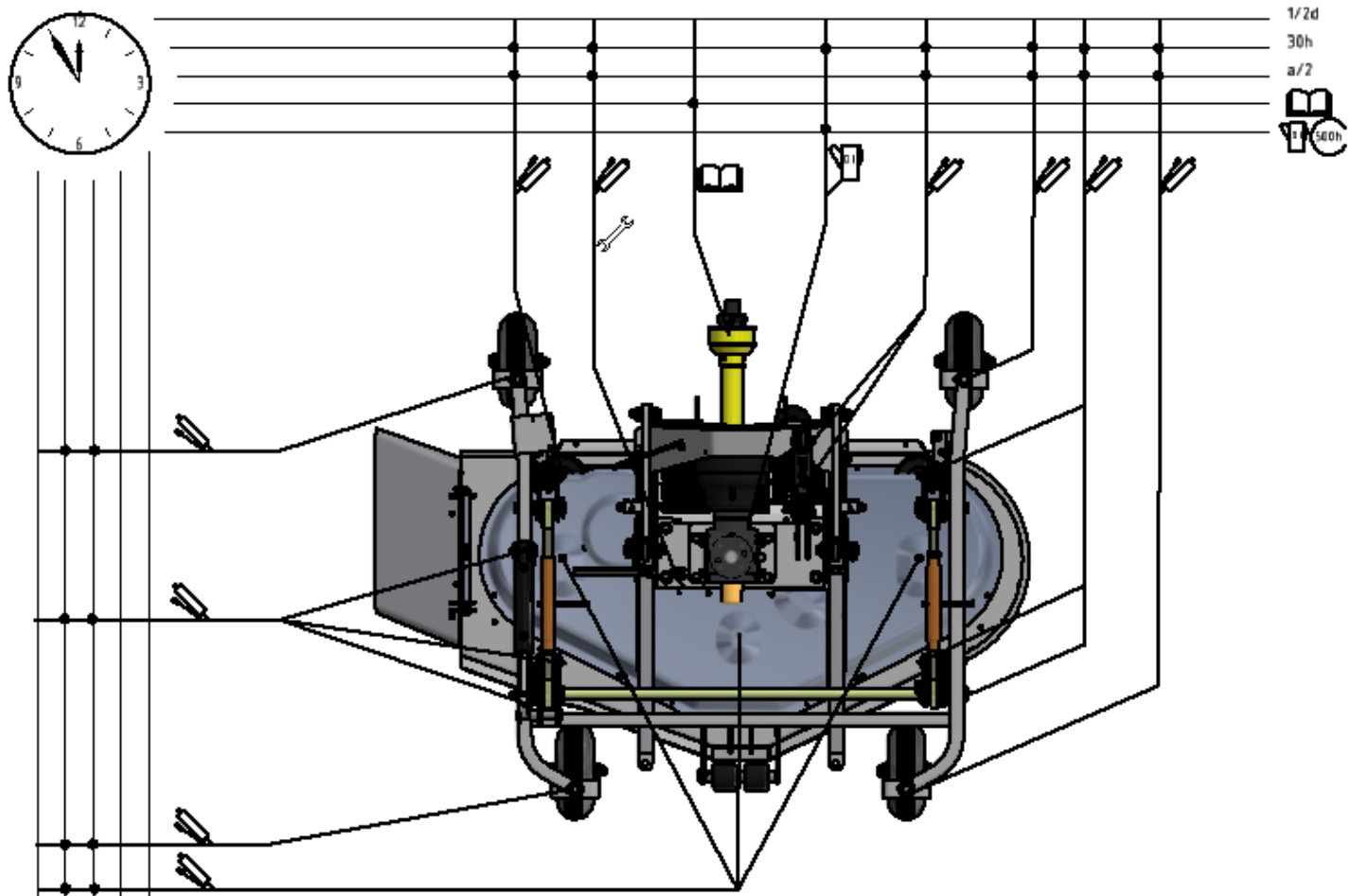
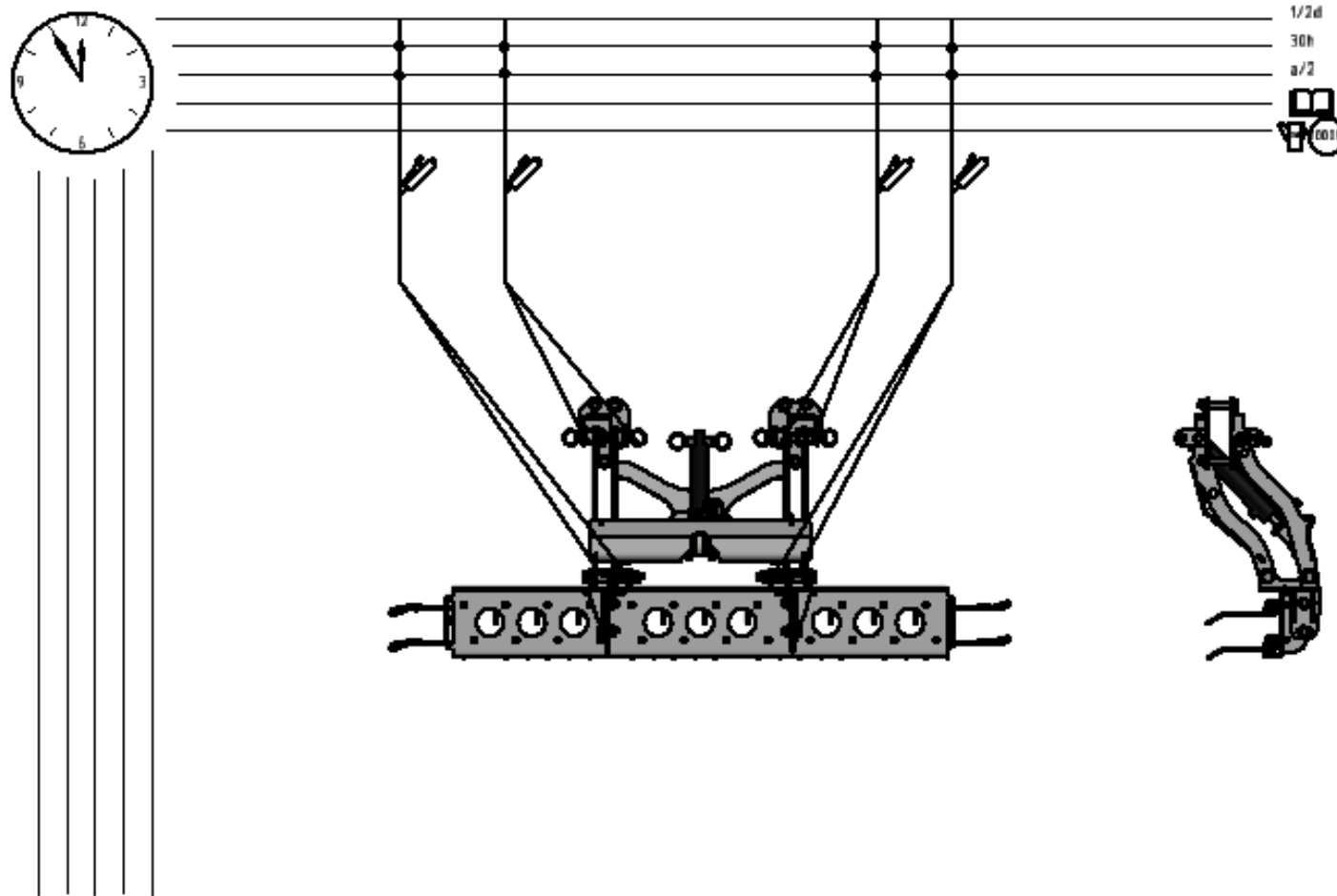



## 9 Fault

Fault	Possible cause / rectification
Suction hose is clogged	<ul style="list-style-type: none"> <li>• Driving too fast for the given conditions / select an appropriate working speed</li> </ul>
Mower does not start up	<ul style="list-style-type: none"> <li>• Heavy clogging in the mower / switch off the machine immediately, remove the ignition key and clean the mower</li> </ul>
Poor mowing pattern	<ul style="list-style-type: none"> <li>• Driving too fast for the given conditions / select an appropriate working speed</li> <li>• Blade dull / sharpen or replace blade.</li> <li>• Insufficient blade rpm / drive at full throttle</li> <li>• Blades have seized, e.g. due to grass cuttings. Remove blades, clean clog point, lightly oil blade bearing and reassemble. It must be possible to easily move the blades.</li> <li>• For dense grass and low cutting height – insufficient air supply / adjust air regulating disks</li> <li>• Mower incline not correctly adjusted</li> </ul>

Table 3: Fault

---

## 10 Repair

If there are faults, problems, or other indications of malfunction, contact your sales consultant or contact the manufacturer directly:

matev GmbH

Nürnberger Str. 50  
90579 Langenzenn, Germany  
Tel.: +49 (0) 9101 9087-0

[www.matev.eu](http://www.matev.eu)

[info@matev.eu](mailto:info@matev.eu)

Also comply with the following instructions:

- Repairs must only be undertaken in the facilities of specialized companies.
- Only original spare parts from matev must be used for repairs.
- Do not modify the machine in any way.

## **11 Disposal**

The implement must be disposed of in accordance with the applicable regulations of the municipality or the country.

Take the parts to the collection points for residual waste, special waste, or recycle them depending on material. Matev GmbH does not provide any disposal services.

## **12 Warranty**

The general terms and conditions of matev GmbH apply.

## 13 List of illustrations

Fig. 1: Definition of alignment and direction of rotation .....	5
Fig. 2: Hydraulic power diagram.....	7
Fig. 3: Protective cover for gearbox .....	12
Fig. 4: Belt guard (drive).....	13
Fig. 5: Adapter fixation on the front lift.....	13
Fig. 6: Side discharge cover .....	14
Fig. 7: Port with suction hose .....	14
Fig. 8: Mulch insert for mower .....	15
Fig. 9: Rear discharge without suction unit .....	15
Fig. 10: Rear discharge with suction unit .....	16
Fig. 11: Warning sign on the right attachment bracket.....	17
Fig. 12: Warning sign on the left attachment bracket.....	17
Fig. 13: Warning sign on the basic deck (right side discharge).....	18
Fig. 14: Warning sign on the basic deck (right side discharge rear) .....	18
Fig. 15: Warning sign – mower blades .....	19
Fig. 16: Warning signs .....	19
Fig. 17: Optional accessories .....	23
Fig. 18: Clean the work terrain .....	24
Fig. 19: Irregular areas .....	25
Fig. 20: Mowing large areas .....	25
Fig. 21: Mowing small areas.....	25
Fig. 22: Mounting the mower on the carrier vehicle .....	26
Fig. 23: Suction port .....	28
Fig. 24: Rock guard on side ejection .....	29
Fig. 25: Safeguard with locking pin .....	30
Fig. 26: Transport position.....	31
Fig. 27: Adjusting the inclination on the mower.....	31
Fig. 28: Adjusting the inclination angle on the driving frame.....	32
Fig. 29: Measuring tool .....	32
Fig. 30: Caster on the mower .....	33
Fig. 31: Hydraulic frame .....	34
Fig. 32: Scale on the cylinder .....	34
Fig. 33: The shut-off valves "Turn in maintenance position" .....	35
Fig. 34: Position of the wheels for maintenance position .....	35
Fig. 35: Mower in maintenance position.....	36
Fig. 36: The shut-off valves "Secure in maintenance position" .....	36
Fig. 37: Adjusting the air intake .....	37
Fig. 38: Transport position of the harrow.....	38
Fig. 39: Harrow position in operation.....	39
Fig. 40: Adjusting the angle of inclination of the tines. ....	40
Fig. 41: Stroke limitation .....	41
Fig. 42: V-belt run for the MOW 140 .....	43
Fig. 43: V-belt run for the MOW 160 .....	44
Fig. 44: V-belt run for the MOW 190 .....	44

## 14 List of tables

Table 1: Technical data .....	6
Table 2: Lubrication schedule symbols .....	45
Table 3: Fault.....	48

## 15 EG – Declaration of Conformity

EC Declaration of Conformity for a machine to confirm compliance with Directive 2006/42/EC and with the statutory regulations issued for its implementation.

The manufacturer

matev GmbH  
Nürnberger Str.50  
90579 Langenzenn, Germany

declares that the machines MOW-HM 140/160/190CM

comply with the provisions of the Machinery Directive 2006/42/EC and with the implementing national statutory regulations.

The signatory is authorized to compile the technical documents.

The address is the address of the manufacturer.

Date / signature November 2020

A handwritten signature in black ink, appearing to read 'Michael Volz', with a stylized flourish at the end.

Name of signer Michael Volz

Signer information Managing Director